



EN

KO

VN

THAI

ID

繁中

# Quick Start Guide

[www.ezvizlife.com](http://www.ezvizlife.com)

COPYRIGHT © 2019 Hangzhou EZVIZ Software Co., Ltd.. ALL RIGHTS RESERVED.

Any and all information, including, among others, wordings, pictures, graphs are the properties of Hangzhou EZVIZ Software Co., Ltd. (hereinafter referred to as "EZVIZ"). This user manual (hereinafter referred to as "the Manual") cannot be reproduced, changed, translated, or distributed, partially or wholly, by any means, without the prior written permission of EZVIZ. Unless otherwise stipulated, EZVIZ does not make any warranties, guarantees or representations, express or implied, regarding to the Manual.

### **About this Manual**

The Manual includes instructions for using and managing the product. Pictures, charts, images and all other information hereinafter are for description and explanation only. The information contained in the Manual is subject to change, without notice, due to firmware updates or other reasons. Please find the latest version in the

**EZVIZ™** website (<http://www.evizlife.com>).

### **Revision Record**

New release – January, 2019

### **Trademarks Acknowledgement**

**EZVIZ™**, ™, and other EZVIZ's trademarks and logos are the properties of EZVIZ in various jurisdictions. Other trademarks and logos mentioned below are the properties of their respective owners.

### **Legal Disclaimer**

TO THE MAXIMUM EXTENT PERMITTED BY APPLICABLE LAW, THE PRODUCT DESCRIBED, WITH ITS HARDWARE, SOFTWARE AND FIRMWARE, IS PROVIDED "AS IS", WITH ALL FAULTS AND ERRORS, AND EZVIZ MAKES NO WARRANTIES, EXPRESS OR IMPLIED, INCLUDING WITHOUT LIMITATION, MERCHANTABILITY, SATISFACTORY QUALITY, FITNESS FOR A PARTICULAR PURPOSE, AND NON-INFRINGEMENT OF THIRD PARTY. IN NO EVENT WILL EZVIZ, ITS DIRECTORS, OFFICERS, EMPLOYEES, OR AGENTS BE LIABLE TO YOU FOR ANY SPECIAL, CONSEQUENTIAL, INCIDENTAL, OR INDIRECT DAMAGES, INCLUDING, AMONG OTHERS, DAMAGES FOR LOSS OF BUSINESS PROFITS, BUSINESS INTERRUPTION, OR LOSS OF DATA OR DOCUMENTATION, IN CONNECTION WITH THE USE OF THIS PRODUCT, EVEN IF EZVIZ HAS BEEN ADVISED OF THE POSSIBILITY OF SUCH DAMAGES.

TO THE MAXIMUM EXTENT PERMITTED BY APPLICABLE LAW, IN NO EVENT SHALL EZVIZ'S TOTAL LIABILITY FOR ALL DAMAGES EXCEED THE ORIGINAL PURCHASE PRICE OF THE PRODUCT.

EZVIZ DOES NOT UNDERTAKE ANY LIABILITY FOR PERSONAL INJURY OR PROPERTY DAMAGE AS THE RESULT OF PRODUCT INTERRUPTION OR SERVICE TERMINATION CAUSED BY: A) IMPROPER INSTALLATION OR USAGE OTHER THAN AS REQUESTED; B) THE PROTECTION OF NATIONAL OR PUBLIC INTERESTS; C) FORCE MAJEURE; D) YOURSELF OR THE THIRD PARTY, INCLUDING WITHOUT LIMITATION, USING ANY THIRD PARTY'S PRODUCTS, SOFTWARE, APPLICATIONS, AND AMONG OTHERS.

REGARDING TO THE PRODUCT WITH INTERNET ACCESS, THE USE OF PRODUCT SHALL BE WHOLLY AT YOUR OWN RISKS. EZVIZ SHALL NOT TAKE ANY RESPONSIBILITIES FOR ABNORMAL OPERATION, PRIVACY LEAKAGE OR OTHER DAMAGES RESULTING FROM CYBER ATTACK, HACKER ATTACK, VIRUS INSPECTION, OR OTHER INTERNET SECURITY RISKS; HOWEVER, EZVIZ WILL PROVIDE TIMELY TECHNICAL SUPPORT IF REQUIRED.

SURVEILLANCE LAWS AND DATA PROTECTION LAWS VARY BY JURISDICTION. PLEASE CHECK ALL RELEVANT LAWS IN YOUR JURISDICTION BEFORE USING THIS PRODUCT IN ORDER TO ENSURE THAT YOUR USE CONFORMS TO THE APPLICABLE LAW. EZVIZ SHALL NOT BE LIABLE IN THE EVENT THAT THIS PRODUCT IS USED WITH ILLEGITIMATE PURPOSES.

IN THE EVENT OF ANY CONFLICTS BETWEEN THE ABOVE AND THE APPLICABLE LAW, THE LATTER PREVAILS.

## Regulatory Information

### FCC Information

This device complies with Part 15 of the FCC Rules. Operation is subject to the following two conditions:

- (1) This device may not cause harmful interference, and
- (2) This device must accept any interference received, including interference that may cause undesired operation.

Note: This product has been tested and found to comply with the limits for a Class B digital device, pursuant to Part 15 of the FCC Rules. These limits are designed to provide reasonable protection against harmful interference in a residential installation. This product generates, uses, and can radiate radio frequency energy and, if not installed and used in accordance with the instructions, may cause harmful interference to radio communications. However, there is no guarantee that interference will not occur in a particular installation. If this product does cause harmful interference to radio or television reception, which can be determined by turning the equipment off and on, the user is encouraged to try to correct the interference by one or more of the following measures:

- Reorient or relocate the receiving antenna.
- Increase the separation between the equipment and receiver.
- Connect the equipment into an outlet on a circuit different from that to which the receiver is connected.
- Consult the dealer or an experienced radio/TV technician for help.

Please take attention that changes or modification not expressly approved by the party responsible for compliance could void the user's authority to operate the equipment.

This equipment should be installed and operated with a minimum distance 20cm between the radiator and your body.

This device complies with Industry Canada licence-exempt RSS standard(s). Operation is subject to the following two conditions:

- (1) this device may not cause interference, and
- (2) this device must accept any interference, including interference that may cause undesired operation of the device.

Under Industry Canada regulations, this radio transmitter may only operate using an antenna of a type and maximum (or lesser) gain approved for the transmitter by Industry Canada. To reduce potential radio interference to other users, the antenna type and its gain should be so chosen that the equivalent isotropically radiated power (e.i.r.p.) is not more than that necessary for successful communication.



#### EU Conformity Statement

This product and - if applicable - the supplied accessories too are marked with "CE" and comply therefore with the applicable harmonized European standards listed under the Radio Equipment Directive 2014/53/EU, the EMC Directive 2014/30/EU, the RoHS Directive 2011/65/EU.



2012/19/EU (WEEE directive): Products marked with this symbol cannot be disposed of as unsorted municipal waste in the European Union. For proper recycling, return this product to your local supplier upon the purchase of equivalent new equipment, or dispose of it at designated collection points. For more information see: [www.recyclethis.info](http://www.recyclethis.info).



2006/66/EC and its amendment 2013/56/EU (battery directive): This product contains a battery that cannot be disposed of as unsorted municipal waste in the European Union.



See the product documentation for specific battery information. The battery is marked with this symbol, which may include lettering to indicate cadmium (Cd), lead (Pb), or mercury (Hg). For proper recycling, return the battery to your supplier or to a designated collection point. For more information see: [www.recyclethis.info](http://www.recyclethis.info).

#### Industry Canada ICES-003 Compliance

This device meets the CAN ICES-3 (B)/NMB-3(B) standards requirements.

## EC DECLARATION OF CONFORMITY

Hereby, Hangzhou EZVIZ Software Co., Ltd . declares that the radio equipment type [CS-CMT-Solar Panel] is in compliance with Directive 2014/53/EU.

The full text of the EC DECLARATION OF CONFORMITY is available at the following web link:  
<http://www.ezvizlife.com/declaration-of-conformity>.

## Safety Instruction

**Due to the product shape and dimension, the name and address of the importer/ manufacturer are printed on the package.**

## Customer Service

For more information, please visit [www.ezvizlife.com](http://www.ezvizlife.com).

Need help? Please visit "[www.ezvizlife.com/inter/page/contact-us](http://www.ezvizlife.com/inter/page/contact-us)" for our local contact details.

**SAVE THIS MANUAL FOR FUTURE REFERENCE**

# Box Content

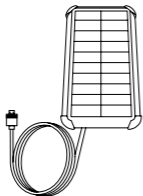

Solar Panel (x1)



Screw Kit (x1)

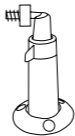

Adjustable Mounting Bracket (x1)



Quick Start Guide (x1)



The solar panel appearance is subject to the actual one you have bought.

# Installation

EN

You can install the solar panel on the wall or ceiling.

- i** CAUTION: As an alternative charging equipment, the power amount generated by this solar panel may be affected by its actual surrounding environment, mainly the intensity of sunlight and the time length of illumination. If the battery camera is running out of power soon, please bear it in mind that this solar panel alone cannot ensure the camera remains in working status.

## 1 Install the bracket

- (For the cement wall/ceiling only) Drill screw holes, and insert three anchors.
- Use three screws to fix the bracket.

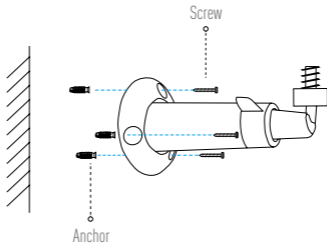

## 2 Install the Solar Panel

- Mount the solar panel on the bracket.
- Tighten the fixing screw.

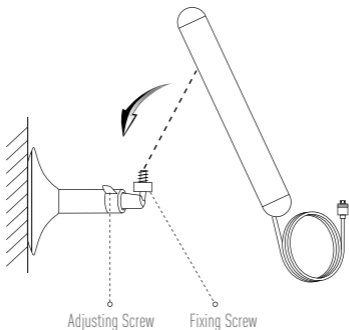

## 3 Adjust the Angle

- Loosen the adjusting screw.
- Adjust the solar panel angle as your desired place.
- Tighten the adjusting screw when you have the solar panel in the position you want.

**i** Make sure that the solar panel receives maximum solar radiation.

#### 4 Charge the Battery Camera

- Connect it with battery camera.

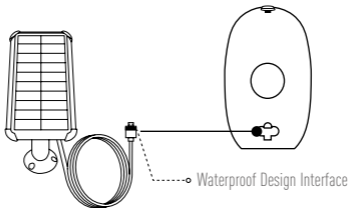

**i** For detailed information, please visit [www.ezvizlife.com](http://www.ezvizlife.com).



#### LIMITED WARRANTY

Thank you for purchasing Hangzhou EZVIZ Software Co., Ltd. ("EZVIZ") products. This limited warranty ("warranty") gives you, the original purchaser of the EZVIZ product, specific legal rights. You may also have other legal rights that vary by state, province or jurisdiction. This warranty applies only to the original purchaser of the product. "Original purchaser" means any consumer having purchased the EZVIZ product from an authorized seller. The disclaimers, exclusions, and limitations of liability under this warranty will not apply to the extent prohibited by applicable law. No distributor, reseller, agent, or employee is authorized to make any modification, extension, or addition to this warranty.

Your EZVIZ product is warranted for a period of one (1) year from the date of purchase against defects in materials and workmanship, or such longer period as may be required by law in the country or state where this product is sold, when used normally in accordance with user manual.

You can request warranty service by contacting our Customer Service.

For any defective EZVIZ products under warranty, EZVIZ will, at its option, (i) repair or replace your product free of charge; (ii) exchange your product with a functional equivalent product; or (iii) refund the original purchase price, provided you provide the original purchase receipt or copy, a brief explanation of the defect, and return the product in its original packaging. At EZVIZ's sole discretion, repair or replacement may be made with a new or refurbished product or components. This warranty does not cover the shipping cost, insurance, or any other incidental charges incurred by you in returning the product. Except where prohibited by applicable law, this is your sole and exclusive remedy for breach of this warranty. Any product that has either been repaired or replaced under this warranty will be covered by the terms of this warranty for the longer of ninety (90) days from the date of delivery or the remaining original warranty period.

This warranty does not apply and is void:

- If the warranty claim is made outside the warranty period or if the proof of purchase is not provided;
- For any malfunction, defect, or failure caused by or resulting from the evidence of impact; mishandling; tampering; use contrary to the applicable instruction manual; incorrect power line voltage; accident; loss; theft; fire; flood; or other Acts of God; shipping damage; or damage resulting from repairs performed by unauthorized personnel;
- For any consumable parts, such as batteries, where the malfunction is due to the normal aging of the product;
- Cosmetic damage, including but not limited to scratches, dents, and broken plastic on ports;
- Any software, even if packaged or sold with EZVIZ hardware;
- For any other damages free from defects in material or workmanship;
- Routine cleaning, normal cosmetic, and mechanical wear and tear.

#### DISCLAIMER OF WARRANTIES

EXCEPT AS STATED ABOVE IN THIS WARRANTY, AND TO THE MAXIMUM EXTENT PERMITTED BY APPLICABLE LAW, EZVIZ DISCLAIMS ALL EXPRESS, IMPLIED, AND STATUTORY WARRANTIES AND CONDITIONS WITH RESPECT TO THE PRODUCT, INCLUDING THE IMPLIED WARRANTIES OF MERCHANTABILITY AND FITNESS FOR A PARTICULAR PURPOSE, THE DURATION OF ANY APPLICABLE IMPLIED WARRANTIES OR CONDITIONS TO THE DURATION OF THIS WARRANTY, THE SECURITY OF THE PRODUCT, OR AVAILABILITY AND RELIABILITY OF PRODUCT INFORMATION OR DATA.

NOTE: SOME STATES OR JURISDICTIONS DO NOT ALLOW LIMITATIONS ON HOW LONG AN IMPLIED WARRANTY LASTS, SO THE ABOVE LIMITATION MAY NOT APPLY TO YOU.

#### LIMITATION OF DAMAGES

IN NO EVENT WILL EZVIZ BE LIABLE FOR ANY CONSEQUENTIAL, INCIDENTAL, EXEMPLARY, OR SPECIAL DAMAGES, INCLUDING ANY DAMAGES FOR LOST DATA OR LOST PROFITS, ARISING FROM OR RELATING TO THIS WARRANTY OR THE PRODUCT, AND EZVIZ'S TOTAL CUMULATIVE LIABILITY ARISING FROM OR RELATED TO THIS WARRANTY OR THE PRODUCT WILL NOT EXCEED THE AMOUNT ACTUALLY PAID FOR THE PRODUCT BY THE ORIGINAL PURCHASER.

NOTE: SOME STATES OR JURISDICTIONS DO NOT ALLOW THE EXCLUSION OR LIMITATION OF INCIDENTAL OR CONSEQUENTIAL DAMAGES, SO THE ABOVE LIMITATION OR EXCLUSION MAY NOT APPLY TO YOU.

#### LIMITATION OF LIABILITY

ALL PRODUCT INFORMATION AND DATA IS PROVIDED FOR YOUR CONVENIENCE, "AS IS", AND "AS AVAILABLE." EZVIZ DOES NOT REPRESENT, WARRANT, OR GUARANTEE THAT PRODUCT INFORMATION AND DATA WILL BE AVAILABLE, ACCURATE, OR RELIABLE OR THAT PRODUCT INFORMATION AND DATA OR USE OF THE PRODUCT WILL PROVIDE SAFETY IN YOUR HOME. YOU USE ALL PRODUCT INFORMATION, DATA, AND THE PRODUCT AT YOUR OWN DISCRETION AND RISK. YOU WILL BE SOLELY RESPONSIBLE FOR (AND EZVIZ DISCLAIMS) ANY AND ALL LOSS, LIABILITY, OR DAMAGES, INCLUDING TO YOUR WIRING, FIXTURES, ELECTRICITY, HOME, PRODUCT, PRODUCT PERIPHERALS, COMPUTER, MOBILE DEVICE, AND ALL OTHER ITEMS AND PETS, RESULTING FROM YOUR USE OF THE PRODUCT INFORMATION, DATA, OR PRODUCT. PRODUCT INFORMATION AND DATA PROVIDED BY EZVIZ IS NOT INTENDED AS A SUBSTITUTE FOR DIRECT MEANS OF OBTAINING THE INFORMATION. FOR EXAMPLE, A NOTIFICATION PROVIDED THROUGH THE PRODUCT IS NOT INTENDED AS A SUBSTITUTE FOR AUDIBLE AND VISIBLE INDICATIONS IN THE HOME AND ON THE PRODUCT, NOR FOR A THIRD PARTY MONITORING SERVICE.

Please do not hesitate to contact your seller or our Customer Service, with any questions.



UD13655B